



寶元數控精密股份有限公司
LNC TECHNOLOGY CO., LTD



寶元數控
永遠是您最好的
事業夥伴

台灣地區

台中總公司

地址：40764台灣台中市西屯區中港路3段 78-2號19F
電話：+886-4-24636889 傳真：+886-4-24635558

彰化測試廠

地址：台灣彰化縣福興鄉福工路 6 號
電話：+886-4-7695300 傳真：+886-4-7687199

大陸地區

東莞寶元數控科技有限公司

地址：廣東省東莞市高鎮高大道三橫路(郵編：523270)
電話：+86-769-88786162 ; +86-769-88786163
傳真：+86-769-88781100

寧波辦事處

地址：浙江省寧波市海曙區段塘東路636號泛亞中心17號702
(郵編：315000)
電話：+86-574-871-22335 ; +86-574-87122393
傳真：+86-574-87122923

昆山辦事處

地址：江蘇省昆山市玉山鎮前進中路 13 號華敏世家花園6棟1201 室
(郵編：215300)
電話：+86-512-57117701 傳真：+86-512-57117707

天津辦事處

地址：天津市河東區渤海創智中心(新開路與華興路交口) 10樓 1004號
(郵編：300011)
電話：+86-22-24335270 傳真：+86-22-24335272

江蘇南通辦事處

地址：南通市世紀園新村(小區) 12號樓 402(郵編：226001)
電話：+86-0513-85206670 傳真：+86-0513-85206670

江蘇常州辦事處

地址：常州市鐘樓區中意寶第花園一幢乙單元302室(郵編：213002)
電話：+86-0519-85699815 傳真：+86-0519-85699815

滕州辦事處

地址：山東省滕州市問天廣場2號樓一單元501室(郵編：277500)
電話：+86-158-22674895

中山辦事處

地址：中山市小欖鎮金菊花園泳菊樓1棟303室(郵編：528415)
電話：+86-13829291586

客服專線：+886-800-561888(國際)
0800-561888(台灣)
800-900-9919(中國大陸)
service@LNC.com.tw



高品質的產品和服務是寶元數控始終如一的定律，有鑒於此，寶元數控提供您從購買前的完整諮詢介紹到售後服務、每一環節廣泛的技術顧問與即時客服。滿足每一位客戶的需要是寶元的最終目的，成長與信賴是寶元數控一貫的做事風格，長期合作關係是我們持續努力的成果與動力。

現今，寶元數控在全球已累積超過3000家設備廠客戶，並且持續性的供貨，為服務每一位客戶，寶元數控也在海外各地設立分公司及服務據點，以提供世界各地的合作夥伴最優質的即時服務。此外，LNC全系列控制器皆通過CE認證，優良的產品品質使我們有十足的信心拓展歐洲市場，強大的海外售服團隊提供您配置到售後每一階段最完善的技術諮詢和最即時的回覆。寶元數控滿足每一位客戶的需求，並朝向世界級品牌的目標邁進。

寶元數控 www.LNC.com.tw
Leading Numerical Controller in the World



LNC-T516i SERIES

提供最佳的解決方案及最高性價比的車床控制器

LNC-T516i系列標準型PC-Based控制器，是寶元數控投入大量研發人力及嚴格的品質管制而獲致的CNC控制器，操作簡便，功能完整，穩定度高且具備及時斷電資料儲存功能。一般可用於車床、各種產業機器及自動化機具。

LNC-T516i SERIES

授權經銷商

硬體規格

- 1) 2伺服軸+1主軸，可選配3伺服軸+1主軸
- 2) 軸向命令格式：標配Pulse command，可選配V command
- 3) 操作面板標準配置手輪，不需額外選配
- 4) 標配I/O點數：20 I/16 O，可再擴充128 I/128 O
- 5) 8" TFT LCD
- 6) 提供RS232及網路功能
- 7) 接線簡單，高性能，all-in-one機種
- 8) LCD前方提供CF卡或USB介面選配
- 9) 模組化操作面板
- 10) 模組化複合式MDI
- 11) OP提供多款選擇，接受客制化需求。

PACK 123架構圖



智慧型開放式高性能控制系統：(★選配)



終端使用者可以利用PC來監視多台NC是否產生異常，當發生異常時，由PC端發送簡訊通知管理人員，機械廠可以利用網路瞭解遠端機台狀況，方便瞭解客戶端的問題，可以達到遠端修復的作用。

軟體功能介紹：

軟體畫面

程式核對



在自動模式下，按下【程式核對】主功能鍵，可進入自動程式核對畫面，右方之子功能鍵提供核對的選項。

標準機能



同時檢示絕對、相對及機械座標。

路徑顯示



可由路徑顯示的功能畫面得知加工輪廓。
可在加工前預覽。

MLC階梯圖顯示

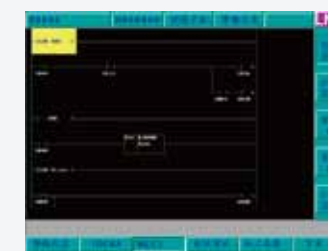

階梯圖顯示。
計數器內容顯示。
變數R及變數D顯示。
計時器的內容顯示。

手輪程式執行功能

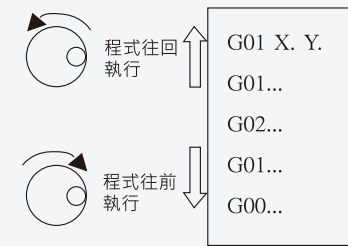

變頻器串列通訊



機構尺寸圖

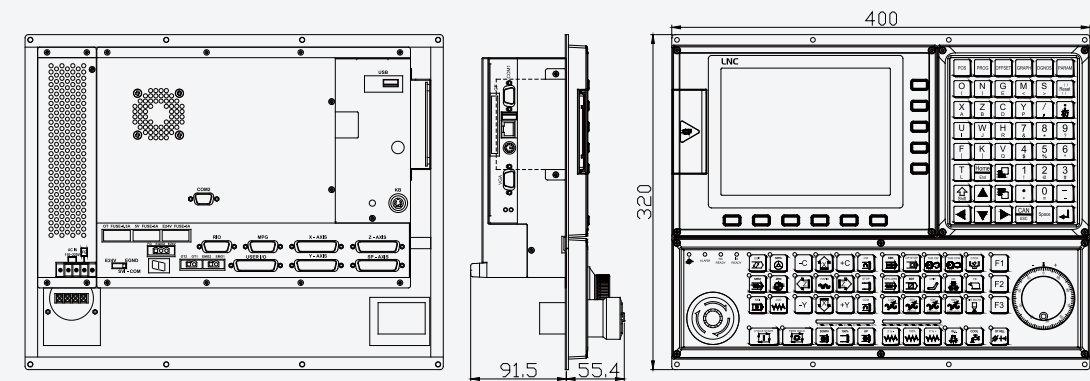

钣金開孔圖

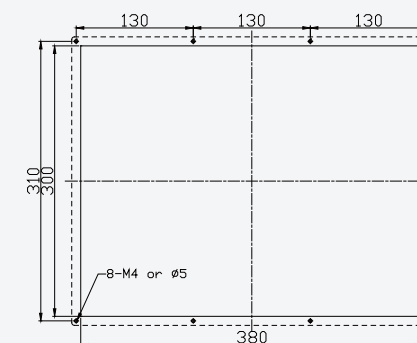

TAIWAN

Head Office-Taichung

19F, No. 78-2, Sec. 3, Taichung Kang Rd., Situn District, Taichung City, 40764 Taiwan

TEL : +886-4-24636889 FAX : +886-4-24635558

Changhua Testing Center

No.6, Fu Kuan Rd., Fu Hsin Hsian, Chang Hwa, Taiwan

TEL : +886-4-7695300 FAX : +886-4-7687199

CHINA

Dongguan Pou Yuen Digital Control Technologic Co., Ltd.

San Hen Rd., Gao Bu Town, Dong Guan City, Guang Dong, China PO: 523270

TEL : +86-769-88786162 ; +86-769-88786163

FAX : +86-769-88781100

Tianjin Office

Room 1004,10th Floor, Bo Hai Chuang Zhi Center (at the crossing of Xin Kai road & Hua Xing road), He Dong District, Tianjin City, China PO: 300011

TEL : +86-22-24335270 FAX : +86-22-24335272

Tengzhou Office

Room 501, Unit 1, Building #2, Win Ten Plaza, Tengzhou, Shandong, China PO:277500

TEL : +86-150-69133273 ; +86-151-69169198

Nantong Office

Room 402, Building #12, New Village area, Century Place Chongchuan District, Nantong, Jiangsu, China PO:226000

TEL : +86-0513-85206670 FAX : +86-0513-85206670

Changzhou Office

Room 302, Unit B, Building #1, Chung Yi Bao Di Garden, Changzhou, Jiangsu, China PO:226000

TEL : +86-0519-85699815 FAX : +86-0519-85699815

Kunshan Office

Room 1201, Building #6, Huamin Gentlefolk Garden, No.13, Cian Jin Central Rd., Kunshan City, Jiangsu Province, China PO:215300

TEL : +86-512-57117701 FAX : +86-512-5711770

Ningbo Office

Room 702, No.17 Pan-Aisa Center, No.636, Road Duan Tang East, Haishu District, Ningbo, China PO:315000

TEL : +86-574-871-22335 ; +86-574-87122393

FAX : +86-574-87122923

Zhongshan Office

Room 303, Yong Ju Building #1, Jin Ju Garden, Xiaolan, Zhongshan, Guangdong, China PO:528415

TEL : +86-138-29291586

Service Hotline: +886-800-561888 (International)

0800-561888 (Taiwan)

800-900-9919 (China)

Mail/Contact Us: Service@LNC.com.tw



**You can
be assured
that we will
be there
for you**

Offering high quality products and service are our promise to each customer. For this reason, LNC provides comprehensive consultation and immediate customer service at all stage of the process, from pre-sales assistance to after sales service. Our goal is satisfaction of each customer. Continually growth and clients' trust is our main target. Long-term relationship is the reason that motivates us.

Nowadays, LNC Technology Corporation has more than 3000 customers around the world with continually orders. For better customer service, LNC sets up a strong overseas service team. Moreover, our controllers all received the CE certifications. LNC Co. is well prepared for the European market. With strong overseas service team, LNC provides comprehensive consultation and immediate customer service, from pre-sales assistance to after sales service. Furthermore, LNC Co. satisfies every customer's needs and get forward to the world class numerical controller brand.



LNC-T516i SERIES

The Revolutionary Lathe Controller with Larger Screen

The brand new LNC-T516i series controller is perfect for lathe application. Now rocking an unique stylish operation panel, an outstanding 3D appearance, data storage before power lose, and a larger screen in 8 inch LCD monitor for your viewing pleasure.

This innovative LNC-T516i series also offer you total solution with PACK1- servo motors, PACK 2 - LNC inverter, and PACK 3 - LNC spindle motor.

Authorized Distributor

LNC-T516i

HARDWARE SPECIFICATIONS

- 1) 2 servo axes +1 spindle, or 3 servo axes +1 spindle(optional)
- 2) Axes command format : Pulse command(standard), V command (optional)
- 3) Operation panel has MPG on it, no need to purchase another one.
- 4) I/O : 20 I/16 O, can be expanded up to 128 I/128 O
- 5) 8" TFT LCD
- 6) RS232, ethernet
- 7) Easy wiring, high performance, all in one type.
- 8) We offer CF card or USB interface on the front of LCD.
- 9) Module type OP
- 10) Module type MDI
- 11) Multi-selection of OP for choosing, customized ones are available.

PACK 123 Configuration

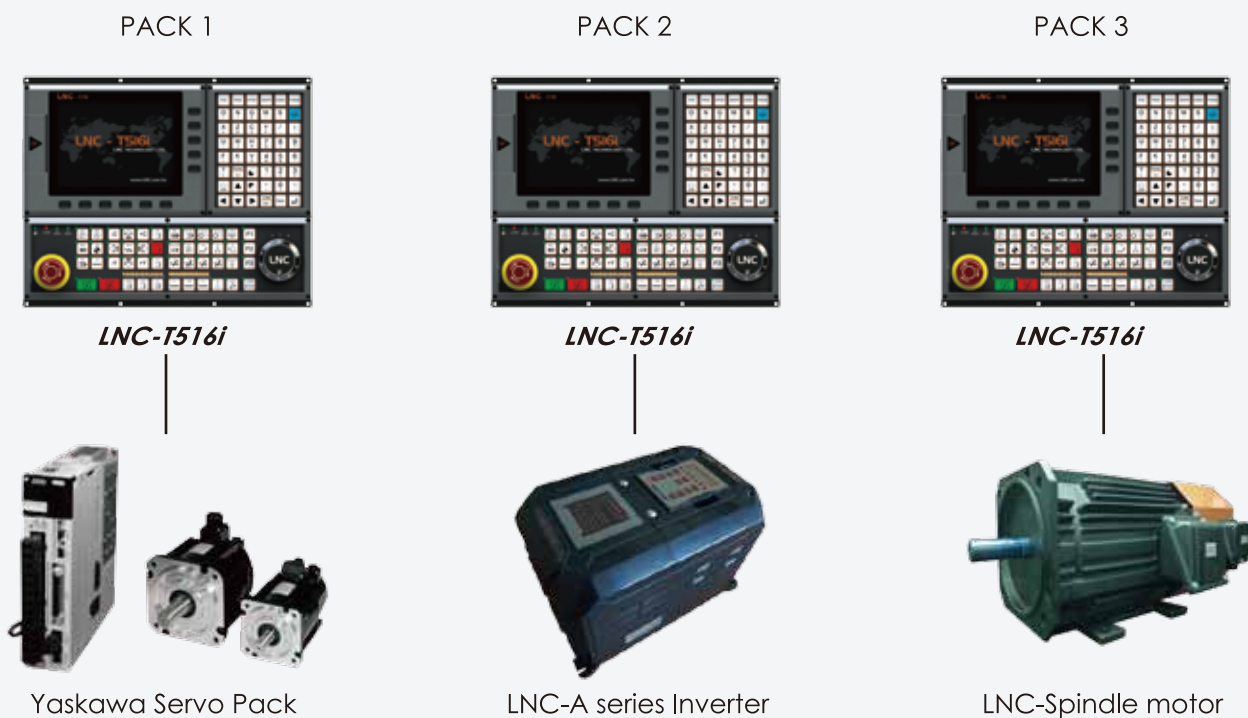

Intelligent Remote Control System - Recon Software (optional)



End user can use PC to monitor multiple NC's situation. When alarm happens, PC side will send message to manage personnel to notify them. Machine makers can use Recon-maintenance software to know remote machines' problems.

SOFTWARE SPECIFICATIONS

Software Screens

Program Check



At the MEM mode, press Program Check main function button to enter program check screen. At the right side there are sub-function buttons for checking.

Standard POS



Show absolute, relative, machine coordinates at the same time on POS group.

Path Preview



This function can be used before processing part program. Users can know processing shape from the path preview function page.

MLC Ladder

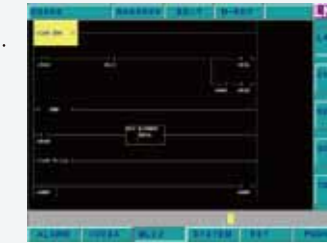

- Show Ladder
- Show numbers counter content
- Show variable R and D
- Show time counter content

MPG Function

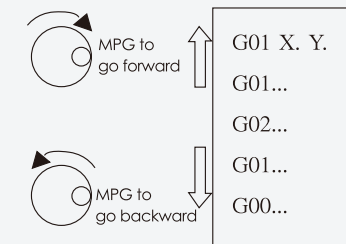

Inverter Serial Communication



Dimension

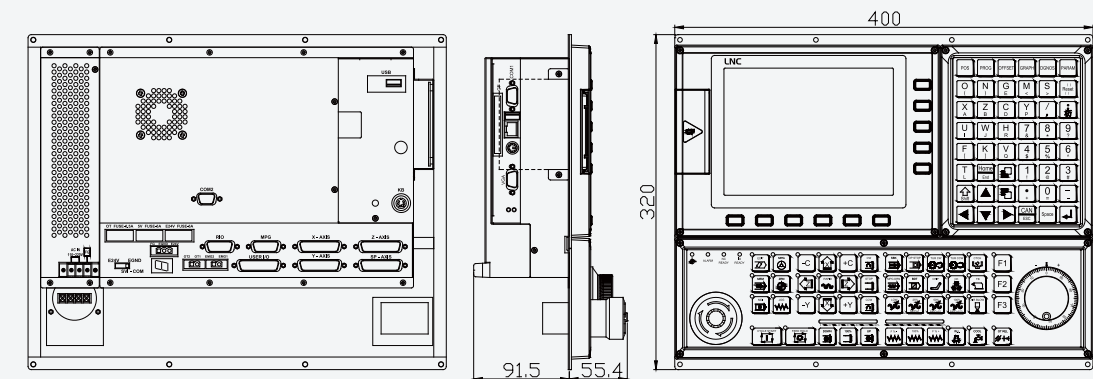

Chassis

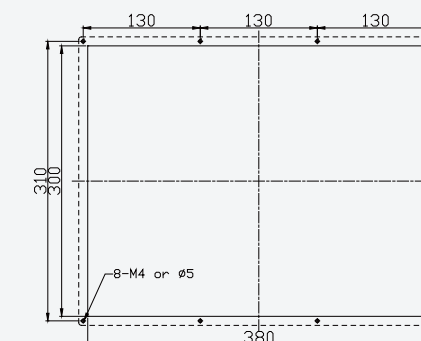



寶元數控精密股份有限公司
LNC TECHNOLOGY CO., LTD

台灣地區

台中總公司
地址：40764台灣台中市西屯區中港路3段 78-2號19F
電話：+886-4-24636889 傳真：+886-4-24635558

彰化測試廠
地址：台灣彰化縣福興鄉福工路 6 號
電話：+886-4-7695300 傳真：+886-4-7687199

大陸地區

東莞寶元數控科技有限公司
地址：廣東省東莞市高鎮高大道三橫路(郵編：523270)
電話：+86-769-88786162 ; +86-769-88786163
傳真：+86-769-88781100

寧波辦事處
地址：浙江省寧波市海曙區段塘東路636號泛亞中心17號702
(郵編：315000)
電話：+86-574-871-22335 ; +86-574-87122393
傳真：+86-574-87122923

昆山辦事處
地址：江蘇省昆山市玉山鎮前進中路 13 號華敏世家花園6棟1201室
(郵編：215300)
電話：+86-512-57117701 傳真：+86-512-57117707

天津辦事處
地址：天津市河東區渤海創智中心(新開路與華興路交口) 10樓 1004號
(郵編：300011)
電話：+86-22-24335270 傳真：+86-22-24335272

江蘇南通辦事處
地址：南通市世紀園新村(小區) 12號樓 402(郵編：226001)
電話：+86-0513-85206670 傳真：+86-0513-85206670

江蘇常州辦事處
地址：常州市鐘樓區中意寶第花園一幢乙單元302室(郵編：213002)
電話：+86-0519-85699815 傳真：+86-0519-85699815

滕州辦事處
地址：山東省滕州市問天廣場2號樓一單元501室(郵編：277500)
電話：+86-158-22674895

中山辦事處
地址：中山市小欖鎮金菊花園泳菊樓1棟303室(郵編：528415)
電話：+86-13829291586

客服專線：+886-800-561888(國際)
0800-561888(台灣)
800-900-9919(中國大陸)
service@LNC.com.tw



寶元數控
永遠是您最好的
事業夥伴

高品質的產品和服務是寶元數控始終如一
的定律，有鑒於此，寶元數控提供您
從購買前的完整諮詢介紹到售後服務、
每一環節廣泛的技術顧問與即時客服。
滿足每一位客戶的需要是寶元的最終目的，
成長與信賴是寶元數控一貫的做事
風格，長期合作關係是我們持續努力的
成果與動力。

現今，寶元數控在全球已累積超過3000家
設備廠客戶，並且持續性的供貨，為服
務每一位客戶，寶元數控也在海外各地
設立分公司及服務據點，以提供世界各
地的合作夥伴最優質的即時服務。此外，
LNC全系列控制器皆通過CE認證，優
良的產品品質使我們有十足的信心拓展
歐洲市場，強大的海外售服團隊提供您
配置到售後每一階段最完善的技術諮詢
和最即時的回覆。寶元數控滿足每一位
客戶的需求，並朝向世界級品牌的目標
邁進。

寶元數控 www.LNC.com.tw
Leading Numerical Controller in the World



全新亮相

嶄新外觀
更寬的螢幕
功能完整

LNC- M516i SERIES

體驗高速高精切削功能

提供最佳的解決方案及最高性價比的銑床控制器LNC-M516i系列標準型
PC-Based控制器，是寶元數控投入大量研發人力及嚴格的品質管制而獲致的
CNC控制器，操作簡便，功能完整，穩定度高且具備及時斷電資料儲存功能。一
般可用於銑床、各種產業機器及自動化機具。

授權經銷商

硬體規格

- 1) 3伺服軸+1主軸
- 2) 軸向命令格式：標配Pulse command，可選配V command
- 3) 預留手輪介面，可外接手輪
- 4) 標配I/O點數：20 I/16 O，可再擴充128 I/128 O
- 5) 8" TFT LCD
- 6) 提供RS232、RS422及網路功能
- 7) 接線簡單，高性能，all-in-one機種
- 8) LCD前方提供CF卡或USB介面選配
- 9) 模組化操作面板
- 10) 模組化複合式MDI
- 11) OP提供多款選擇，接受客制化需求
- 12) 面膜增加透明保護層延長按鍵壽命
- 13) 快速定位倍率和主軸倍率
- 14) COM口可接絕對編碼器或搭配寶元數控變頻器做通訊

PACK 123架構圖



智慧型開放式高性能控制系統：(★選配)



終端使用者可以利用PC來監視多台NC是否產生異常，當發生異常時，由PC端發送簡訊通知管理人員，機械廠可以利用網路瞭解遠端機台狀況，方便瞭解客戶端的問題，可以達到遠端修復的作用。

軟體功能介紹：

軟體畫面

程式核對



在自動模式下，按下【程式核對】主功能鍵，可進入自動程式核對畫面，右方之子功能鍵提供核對的選項。

標準機能



同時檢示絕對、相對及機械座標。

路徑顯示

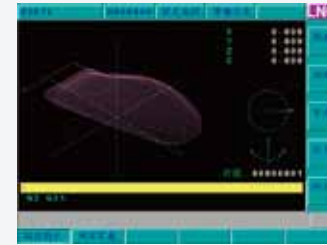

可由路徑顯示的功能畫面得知加工輪廓。
可在加工前預覽。

MLC階梯圖顯示

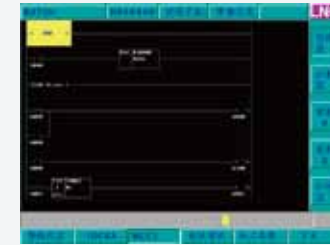

階梯圖顯示。
計數器內容顯示。
變數R及變數D顯示。
計時器的內容顯示。

多單節擬合技術



由CAD轉出的小單節，可以跨越單節，多單節擬合，可以增加加工效率並改善速度不連續造成的粗糙表面。

變頻器串列通訊



機構尺寸圖

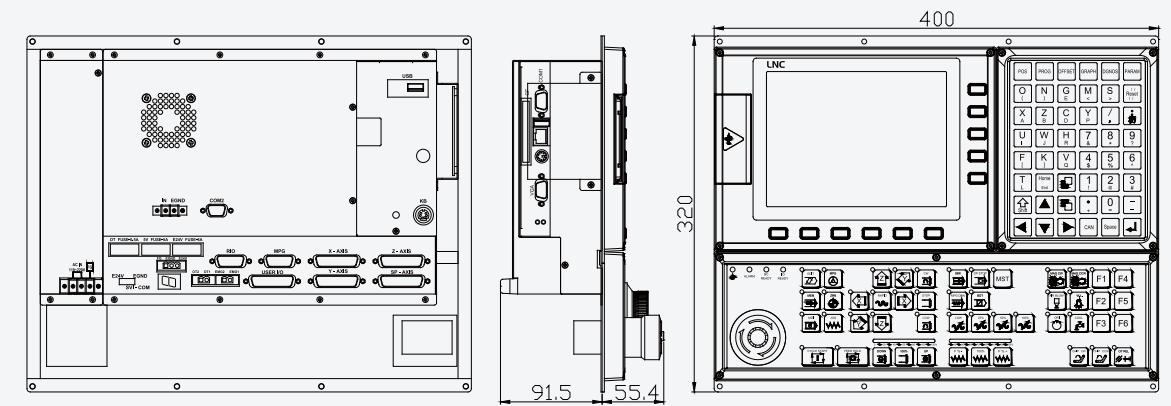

鍍金開孔圖

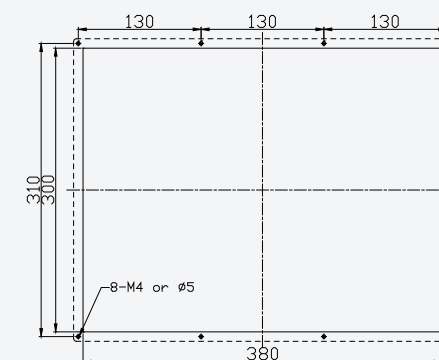

TAIWAN

Head Office-Taichung

19F, No. 78-2, Sec. 3, Taichung Kang Rd., Situn District, Taichung City,
40764 Taiwan
TEL : +886-4-24636889 FAX : +886-4-24635558

Changhua Testing Center

No.6, Fu Kuan Rd., Fu Hsin Hsian, Chang Hwa, Taiwan
TEL : +886-4-7695300 FAX : +886-4-7687199

CHINA

Dongguan Pou Yuen Digital Control Technologic Co., Ltd.

San Hen Rd., Gao Bu Town, Dong Guan City, Guang Dong,China
PO: 523270
TEL : +86-769-88786162 ; +86-769-88786163
FAX : +86-769-88781100

Tianjin Office

Room 1004,10th Floor, Bo Hai Chuang Zhi Center (at the crossing of
Xin Kai road & Hua Xing road), He Dong District, Tianjin City, China
PO: 300011
TEL : +86-22-24335270 FAX : +86-22-24335272

Tengzhou Office

Room 501, Unit 1, Building #2, Win Ten Plaza, Tengzhou, Shandong,
China PO:277500
TEL : +86-150-69133273 ; +86-151-69169198

Nantong Office

Room 402, Building #12, New Village area, Century Place Chongchuan
District, Nantong, Jiangsu, China PO:226000
TEL : +86-0513-85206670 FAX : +86-0513-85206670

Changzhou Office

Room 302, Unit B, Building #1, Chung Yi Bao Di Garden, Changzhou,
Jiangsu, China PO:226000
TEL : +86-0519-85699815 FAX : +86-0519-85699815

Kunshan Office

Room 1201, Building #6, Huamin Gentlefolk Garden, No.13, Cian Jin
Central Rd., Kunshan City, Jiangsu Province, China PO:215300
TEL : +86-512-57117701 FAX : +86-512-5711770

Ningbo Office

Room 702, No.17 Pan-Aisa Center, No.636, Road Duan Tang East,
Haishu District, Ningbo, China PO:315000
TEL : +86-574-871-22335 ; +86-574-87122393
FAX : +86-574-87122923

Zhongshan Office

Room 303, Yong Ju Building #1, Jin Ju Garden, Xiaolan, Zhongshan,
Guangdong, China PO:528415
TEL : +86-138-29291586

☎ Service Hotline: +886-800-561888 (International)
0800-561888 (Taiwan)
800-900-9919 (China)
✉ Mail/Contact Us: Service@LNC.com.tw



**You can
be assured
that we will
be there
for you**

Offering high quality products and service are our promise to each customer. For this reason, LNC provides comprehensive consultation and immediate customer service at all stage of the process, from pre-sales assistance to after sales service. Our goal is satisfaction of each customer. Continually growth and clients' trust is our main target. Long-term relationship is the reason that motivates us.

Nowadays, LNC Technology Corporation has more than 3000 customers around the world with continually orders. For better customer service, LNC sets up a strong overseas service team. Moreover, our controllers all received the CE certifications. LNC Co. is well prepared for the European market. With strong overseas service team, LNC provides comprehensive consultation and immediate customer service, from pre-sales assistance to after sales service. Furthermore, LNC Co. satisfies every customer's needs and get forward to the world class numerical controller brand.



LNC-M516i SERIES

Brand New

Larger screen
Stylish operation panel
Innovative function

The Revolutionary Milling Controller with Larger Screen

The brand new LNC-M516i series controller is perfect for milling application. Now rocking an unique stylish operation panel, an outstanding 3D appearance, data storage before power lose, and a larger screen in 8 inch LCD monitor for your viewing pleasure. High speed/precision is its unique selling proposition. This innovative LNC-M516i series also offer you total solution with PACK1- servo motors, PACK 2 - LNC inverter, and PACK 3 - LNC spindle motor.

LNC-M516i

HARDWARE SPECIFICATIONS

- 1) 3 servo axes +1 spindle
- 2) Axes command format : Pulse command(standard), V command (optional)
- 3) With spare MPG port, external MPG is possible.
- 4) I/O : 20 I/16 O, can be expanded up to 128 I/128 O
- 5) 8" TFT LCD
- 6) RS232, RS422, and ethernet
- 7) Easy wiring, high speed high precision, all in one type.
- 8) We offer CF card or USB interface on the front of LCD.
- 9) Module type OP
- 10) Module type MDI
- 11) Multi-selection of OP for choosing, customized ones are available.
- 12) With transparent protective layer to extend the button lifetime.
- 13) Quick-orientation ratio and spindle ratio.
- 14) Communicate with LNC-A series inverter or ABS encoder with COM port.

PACK 123 Configuration

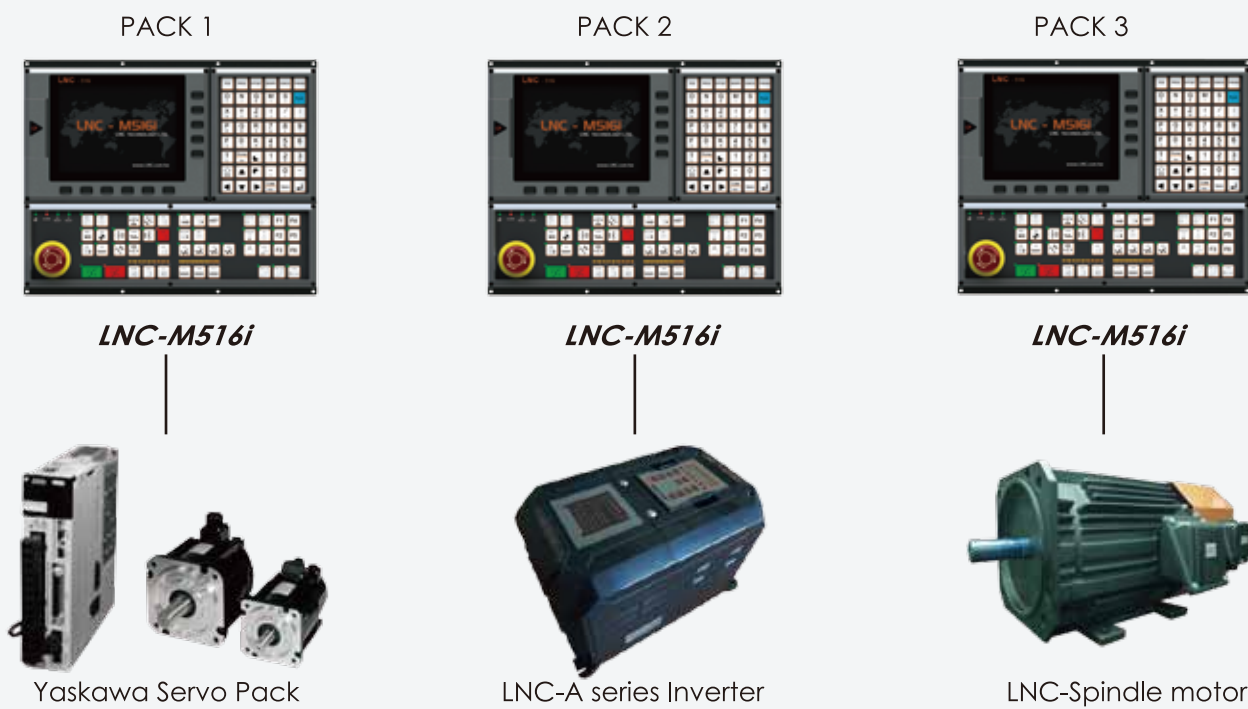

Intelligent Remote Control System - Recon Software (optional)



End user can use PC to monitor multiple NC's situation. When alarm happens, PC side will send message to manage personnel to notify them. Machine makers can use Recon-maintenance software to know remote machines' problems.

SOFTWARE SPECIFICATIONS

Software Screens

Program Check



- At the MEM mode, press Program Check main function button to enter program check screen. At the right side there are sub-function buttons for checking.

Standard POS



- Show absolute, relative, machine coordinates at the same time on POS group.

Path Preview



- This function can be used before processing part program.
- Users can know processing shape from the path preview function page.

MLC Ladder

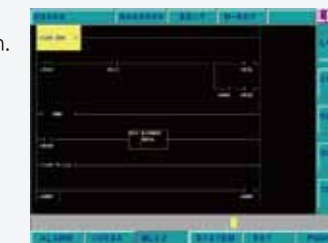

- Show Ladder
- Show numbers counter content
- Show variable R and D
- Show time counter content

Multi-block Combination Function



- Multi-block combination helps to make the small blocks from CAD file to join together to increase processing efficiency and to make the rough surface better which caused by discontinuous speed.

Inverter Serial Communication



Dimension

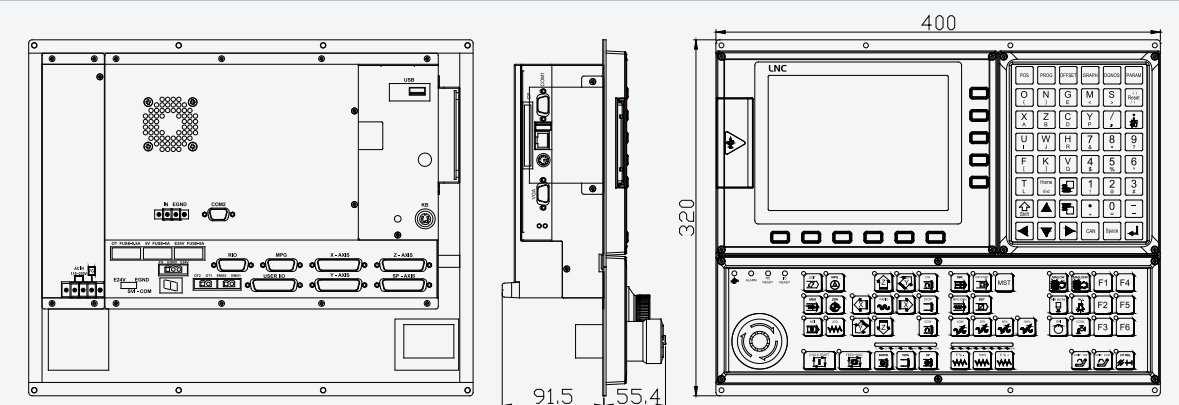

Chassis

